

SECTION Z-Z

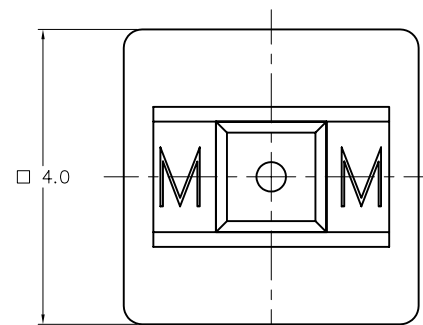

VIEW "Y"

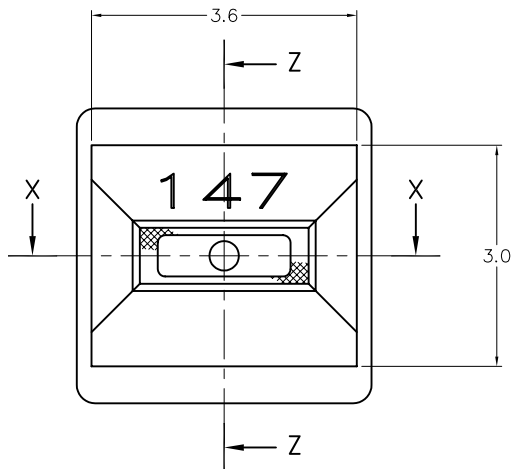
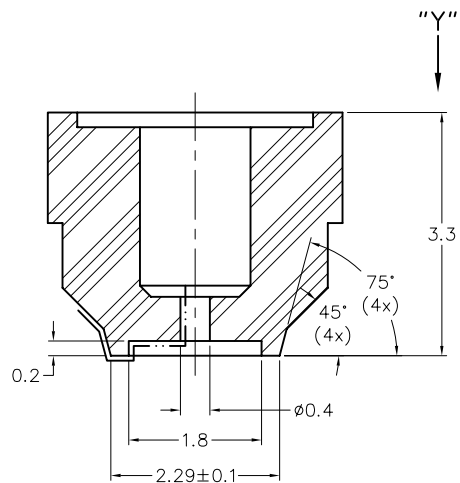

SECTION X-X

- NOTE :
- FLASHFREE AREA, NO VOIDS AND FOREIGN PARTICALS
 - ALL CORNER WITH RADIUS 0.10 MM MAXIMUM

**SALES COPY
UNCONTROLLED DOCUMENT**

Copying of this document and giving it to others and the use of communication of the contents thereof are forbidden without express authority. Offenders are liable to the payment of damages. All rights are reserved in the event of the grant of a patent or the registration of a utility model or design.

TOLERANCE UNLESS SPECIFIED X.X ±0.10 GENERAL TOL. ±0.2 X.XX ±0.05 ANGLE ±0.5° SURFACE FINISH 1.6/√ REMOVE BURRS AND SHARP EDGES ALL DIMENSIONS IN MM. <small>13-99-027 R03</small>	MATERIAL: FLURO  MICRO-MECHANICS PTE LTD mmsingapore@micro-mechanics.com TEL: 67468800 FAX: 67467700	PROCESS: — DATE: 4-5-09 DRAFTSMAN: HT LEK CHECKER: MT HAN	TITLE: RUBBER TIP (12U3 HOLDER) (MOLD #308-2083) SCALE: 15:1 DRAWING NO: HTR3-147	REV. 2 SHEET 1 1